

## USB SideFlipper System

### System Features

- USB Powered and controlled Optical Flipper
- Motorized, flipping of filters, mirrors, or lens
- Holds standard 1.0" (25mm) optics with 1.0" mounting/retaining rings
- Built-in magnetic position sensor provides positive real time feedback of the Flipper's position
- Flipper mounts on standard optical tables with 1/4-20 screws on 1.0" centers
- Low power motor is energized only when lifting the optic (extending). A spring returns it to the retracted position in case of power failure.
- Quiet long life stepper motor operation for extending or retracting the optic (no clunking)
- USB Hot pluggable with Auto-detection
- Easy to use Windows (XP/Vista) based User Interface software, LabView drivers included
- A Quad System comes with four Flippers, an externally powered 4-port USB Hub and 10' (3 meter) USB cables

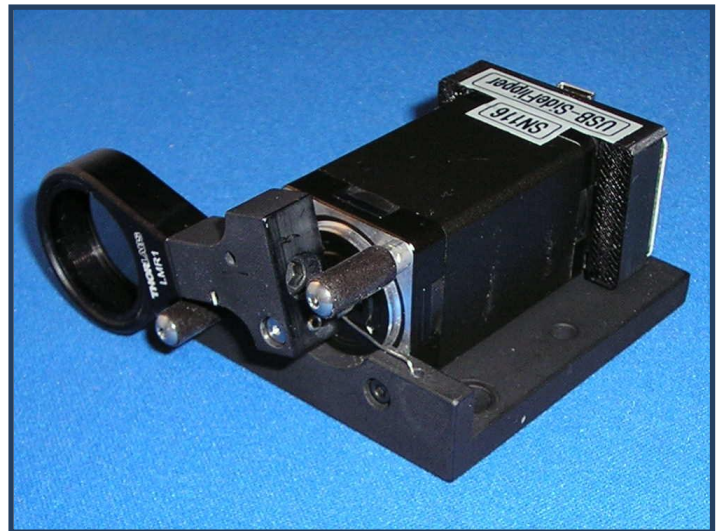

**Single unit for only \$ 475**  
**Complete Quad System \$ 1,865**

**Picard Industries**

4960 Quaker Hill Road, Albion, New York 14411

(585) 589-0358

[info@Picard-Industries.com](mailto:info@Picard-Industries.com)

[www.Picard-Industries.com](http://www.Picard-Industries.com)

## USB Optical Flipper Mechanicals

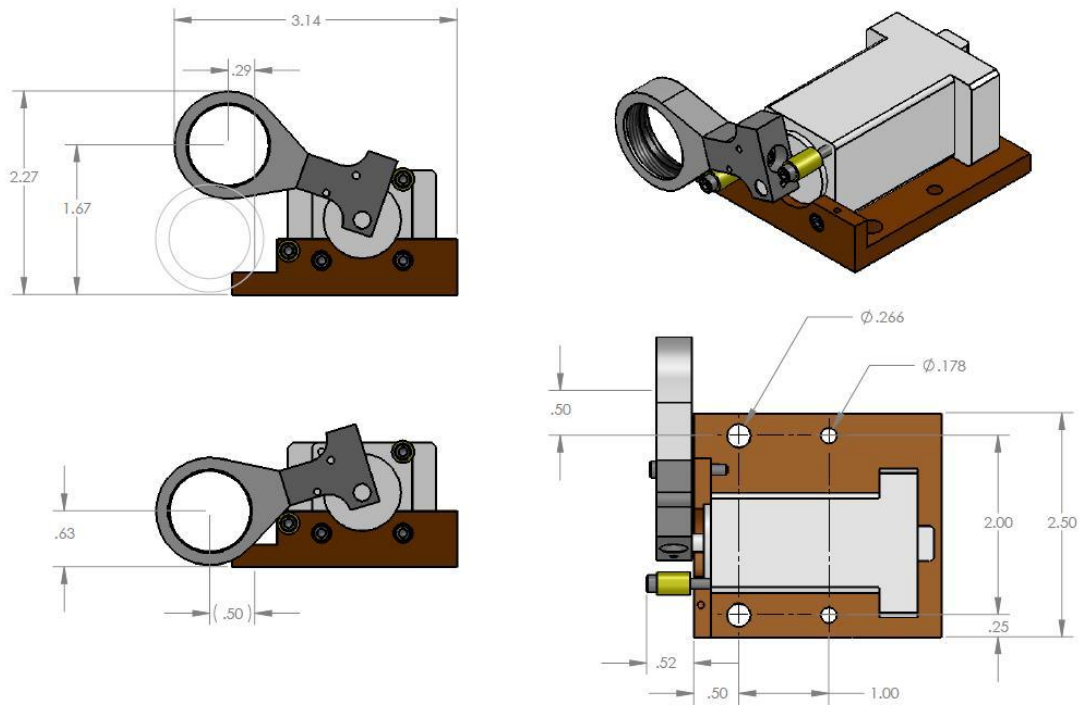

## USB Quad Flipper Software / User Interface

A Windows based user interface is provided for individual control of up to four Optical Flippers. Status (red/green) indicators on the panel will provide indication of whether the Flipper is properly connected and whether it is extended or retracted. The Flip button is clicked to toggle the position of the Flipper. Each Flipper is identified by its serial number located on the Flipper. Descriptive labels can also be assigned to each Flipper. The assignments are stored and activated with the Reset/Store click button. Below is a sample of what the user interface panel looks like.



A DLL (C++) file and LabView examples are also provided to help you integrated the USB-SideFlipper into your automated test system or product application.